

FLEX 2 (FL1002) **28"/35" Adjustable OSHA Step** **Assembly Instructions**

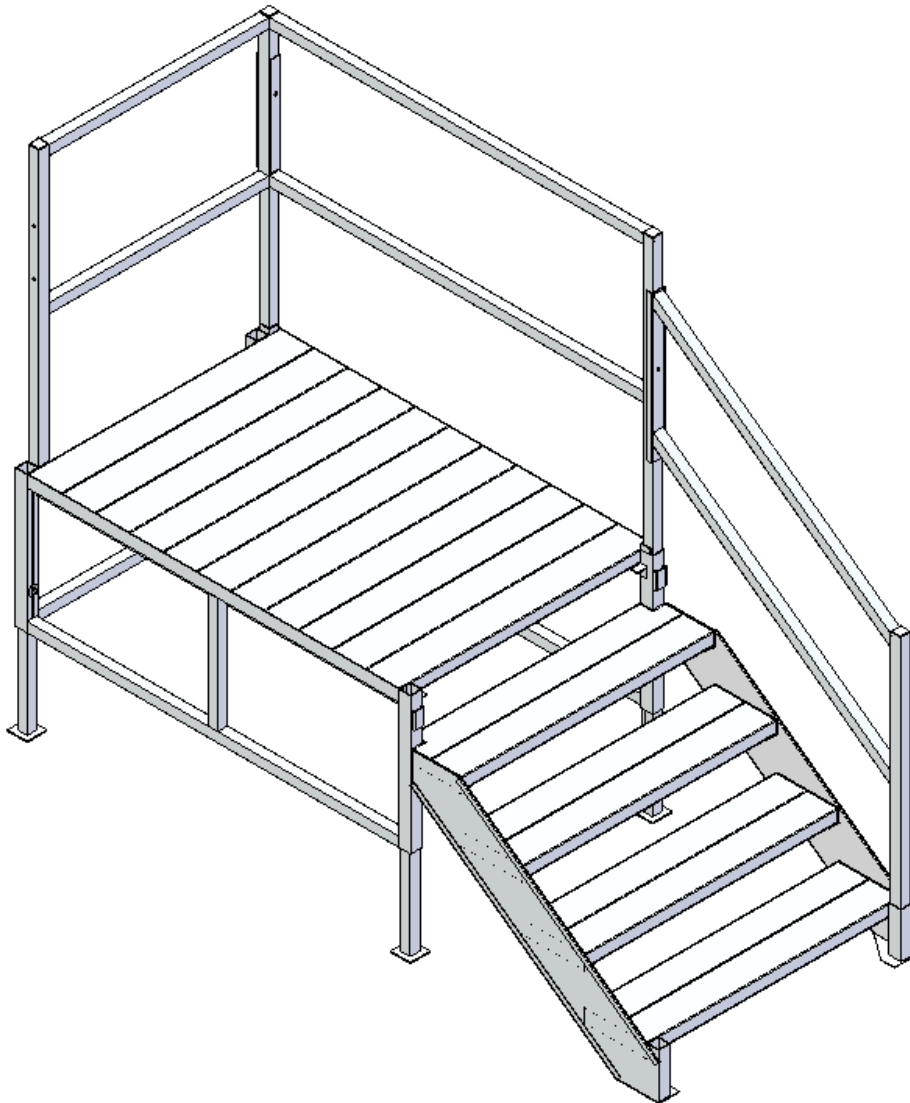

Parts included with assembly:

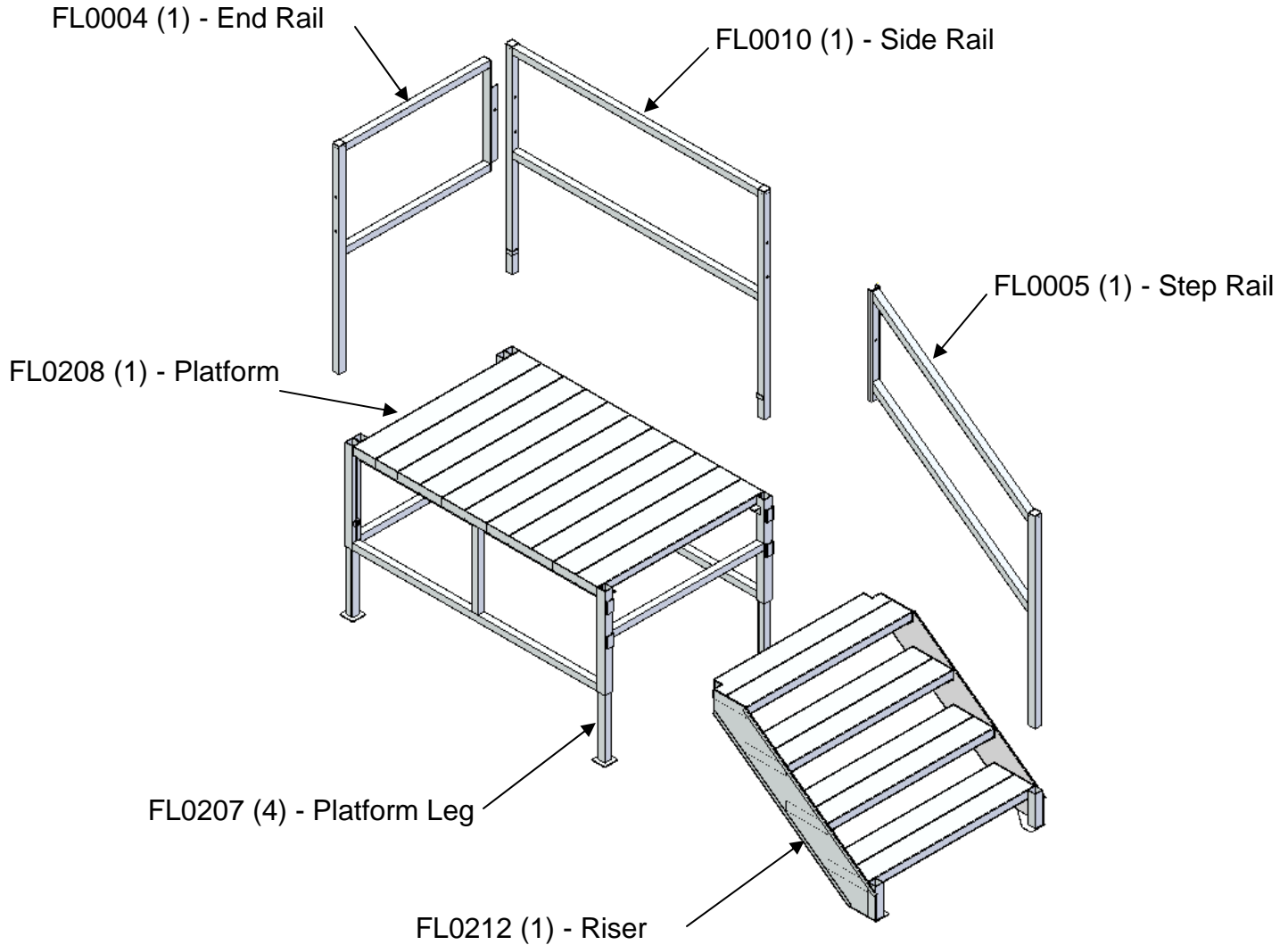

Figure 1: Exploded view of complete assembly.

Additional hardware included with assembly:

- (2) 3/8" x 2-1/2" stainless steel hex bolts
- (2) 3/8" stainless steel washers
- (2) 3/8" stainless steel flange hex nuts
- (4) 1/2" x 1-1/4" stainless steel hex bolts (Pre-assembled at factory)
- (4) 1/2" stainless steel washers (Pre-assembled at factory)

Step 1:

-Lay the platform on its side as shown in **Figure 2**.

-Loosen the four 1/2" bolts on each of the platform corners.

-Slide the four legs out of the platform and set each one at the desired platform height of either 28" or 35". *Note: The 28" or 35" height is measured from the top of the platform to the bottom of the footplate.*

-Tighten each bolt to a torque of 22 to 25 ft-lbs.

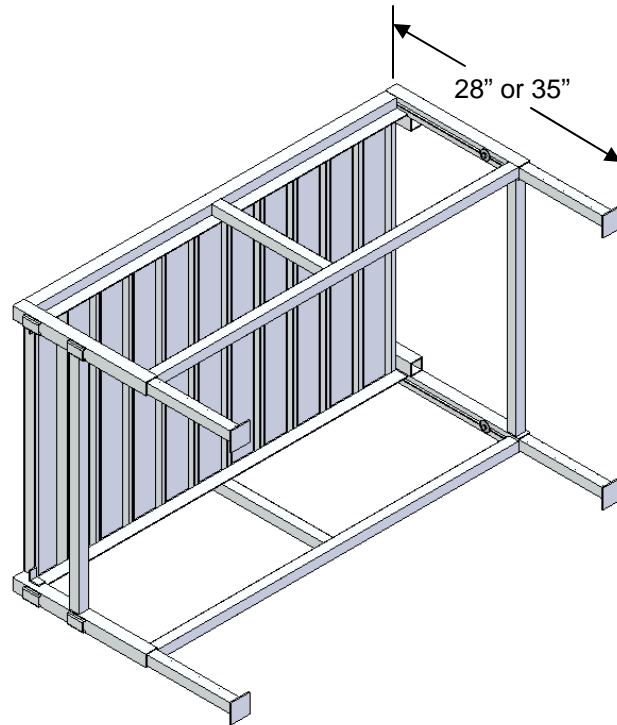

Figure 2: Leg height adjustment.

Step 2:

-Set the platform upright and position it against the building at its final location. If the ground is not level, each leg can be adjusted individually to level the platform. *Note: The platform can be positioned so the steps are on either the right or left side of the door.*

-Slide the two riser hooks into the pockets on the front of the platform. The top pockets are to be used if the platform is at 28" and the bottom pockets are to be used if the platform is at 35". Check that the steps are level. No hardware is required for this step.

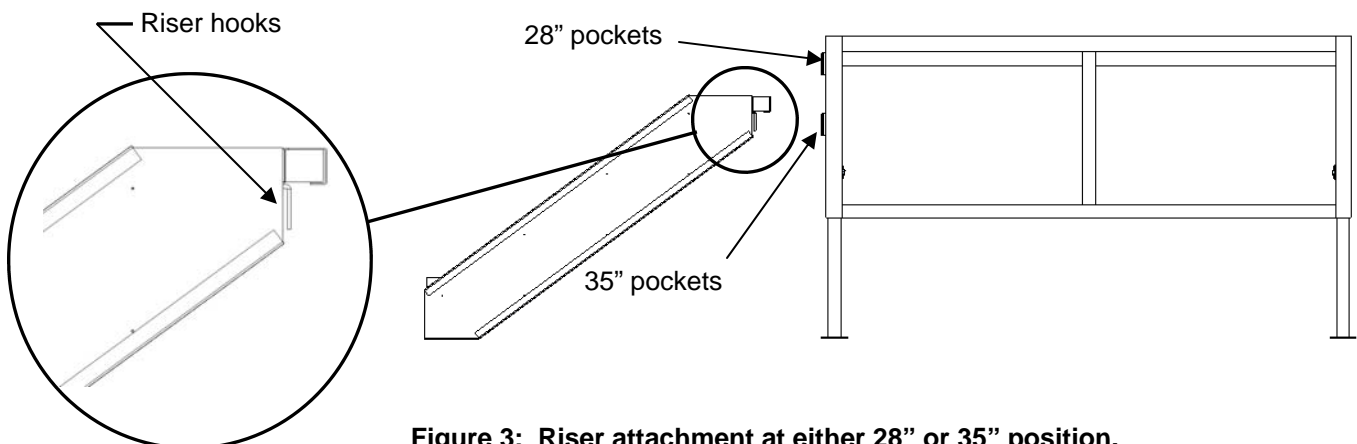

Figure 3: Riser attachment at either 28" or 35" position.

Step 3:

-Insert the side rail into the corner pockets of the platform as shown in **Figure 4**. *Note: The side rail can be inserted on the left or right side of the platform depending on the orientation of the step assembly to the building.*

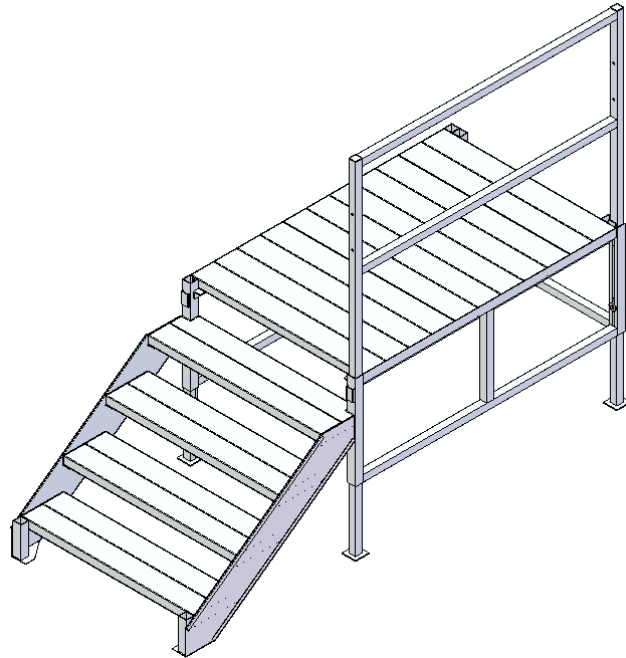

Figure 4: Side rail assembly.

Step 4:

-Insert the end rail into the inside corner pocket on the opposite side of the platform from the steps as shown in **Figure 5**. This feature minimizes any building damage caused by the rail post.

-Use one of the 3/8" x 2-1/2" bolts to attach the end rail to the side rail. The washer is used on the "bolt head" side of the connection. Tighten the flange nut onto the bolt with no more than 20 ft-lbs of torque.

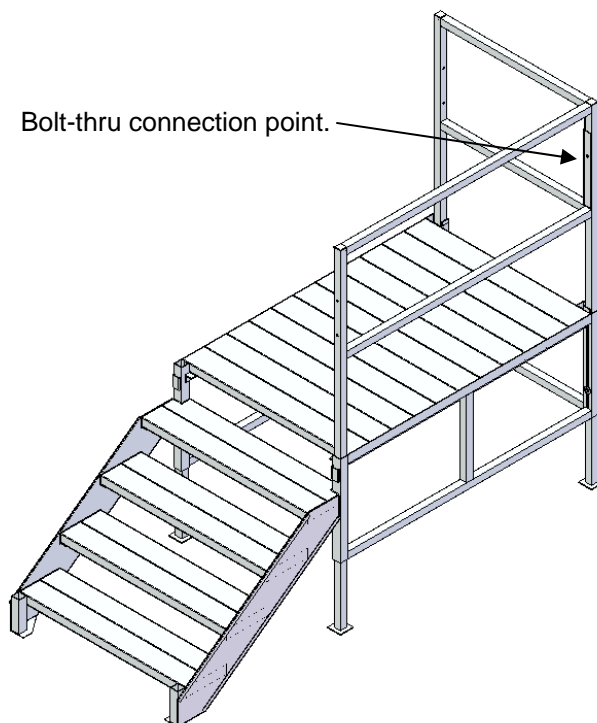

Figure 5: End rail assembly.

Step 5:

-Insert the step rail into the riser pocket at the bottom of the steps as shown in **Figure 6**.

-Use the other $\frac{3}{8}$ " x $2\frac{1}{2}$ " bolt to attach the step rail to the side rail. The washer is used on the "bolt head" side of the connection. Tighten the flange nut onto the bolt with no more than 20 ft-lbs of torque.

-Assembly of the FLEX 2 is now complete.

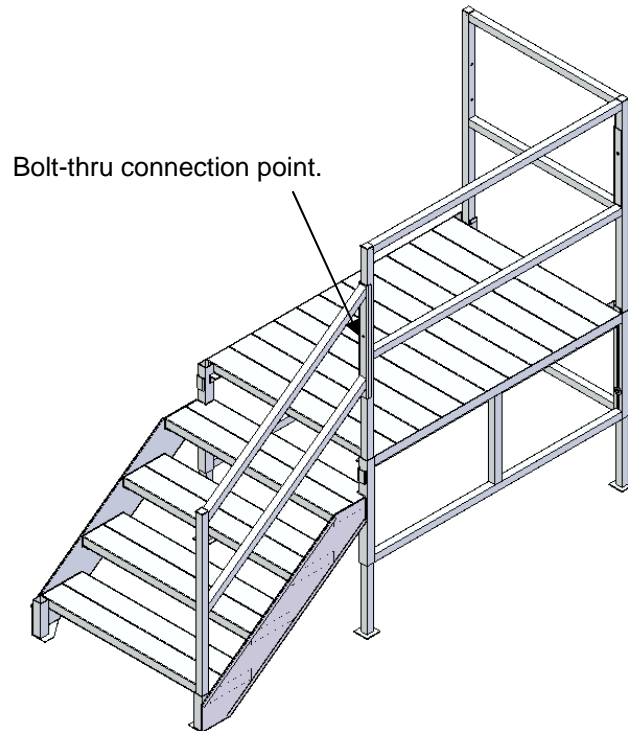

Figure 6: Step rail assembly.

NOTICE: OSHA standard 1926.1050 states that all step risers must be of equal rise and run within $\frac{1}{4}$ ". The FLEX 2 meets this requirement with a consistent 7" rise and 9.5" run. The standard also states that step rails must be between 36" and 37" from the top of the rail to the front edge of each step and that guardrails must be 42" from the platform surface. A midrail must exist half way between the top rail and the walking surface. The FLEX 2 meets all of these requirements as well.

Rev. 1 7/1/10 A.Word