

REDD Team – Assembly Instructions: Stairs



Aluminum Stair System With 5'-0" Square Landing

Table Of Contents

5'-0" x 5'-0" Landing Components	page 01
Stair Components	page 02
Bagged Hardware	page 03
Landing Leg to Landing Installation.....	page 04
Landing to Building Installation	page 05
Landing Rail to Landing Installation.....	page 06
Stair to REDD Team Landing / Existing Landing Installation.....	page 07
Stair Rail Installation & Misc. Connection Detail.....	page 08

5'-0" SQUARE LANDING
AND
COMPONENTS

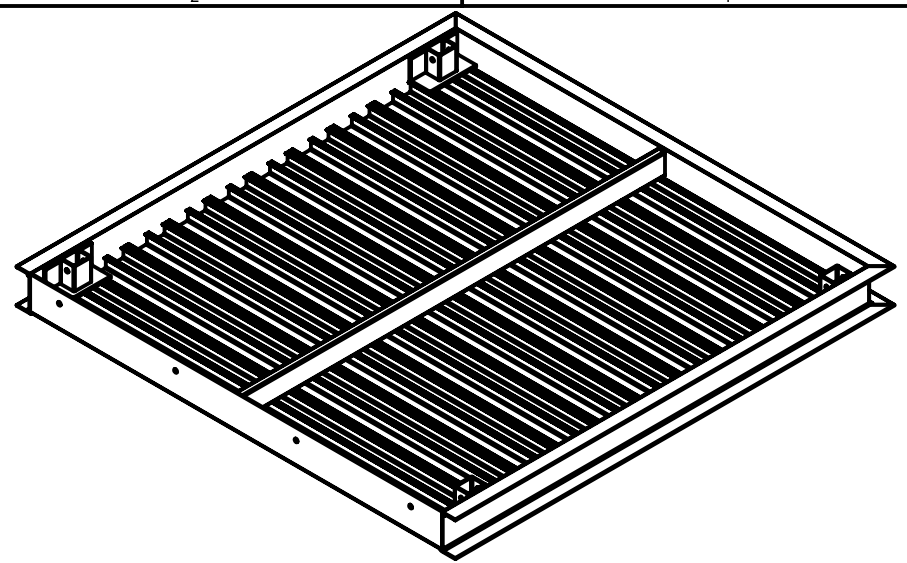

5'-0" x 5'-0" LANDING
LANDING SHOWN UPSIDE DOWN
RTM PART #: L0500X0500T
QTY USED: 1

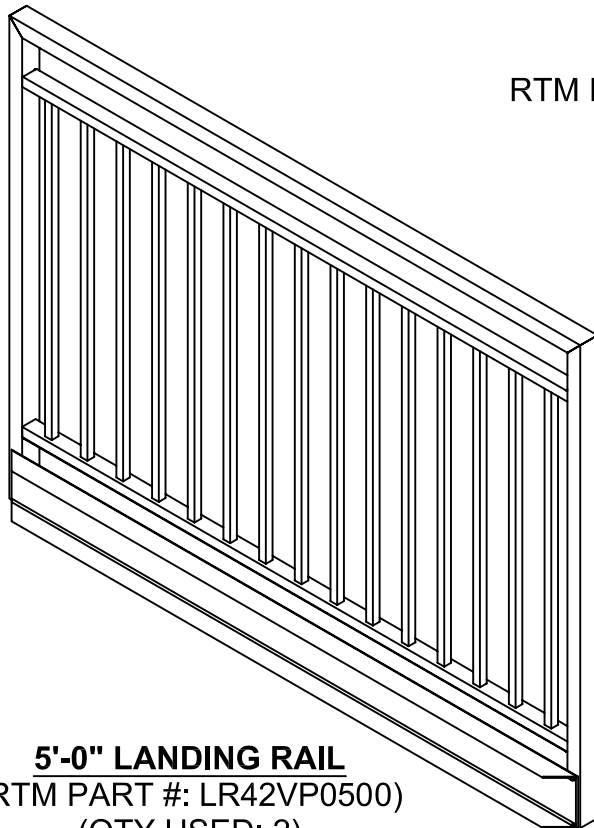

5'-0" LANDING RAIL
(RTM PART #: LR42VP0500)
(QTY USED: 2)

LANDING LEG CONE
RTM PART #: PLEG AS44M C22
QTY USED: 4



LEG ASSEMBLY
RTM PART #: PLEG AS43M 0106
1'-6" LONG
QTY USED: 4

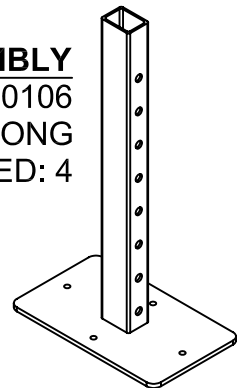

NOTE: RAILS
MAY BE
DIFFERENT
THAN WHAT
IS SHOWN

STAIR COMPONENTS

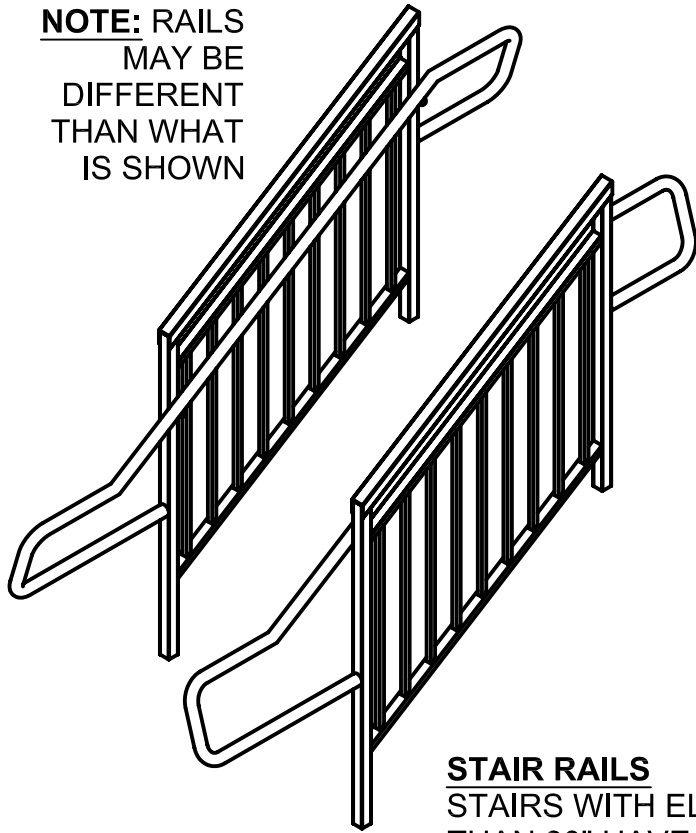

STAIR RAILS
STAIRS WITH ELEVATION LESS
THAN 30" HAVE 34/23 RAILS

ALL OTHERS HAVE 42/34/23 RAILS

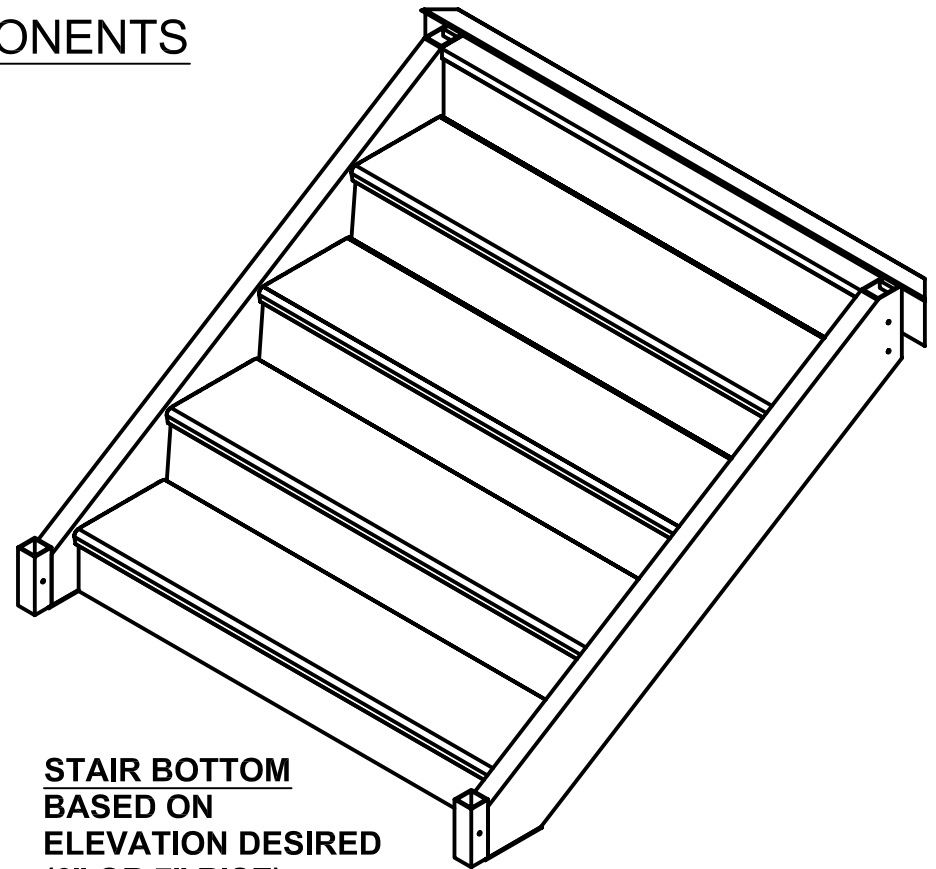

STAIR BOTTOM
BASED ON
ELEVATION DESIRED
(6" OR 7" RISE)

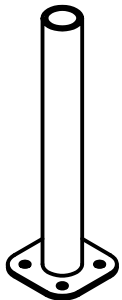

STAIR LEG ADJUSTER
(RTM PART #: PSALEG)
(QTY USED: 2 PER STAIR)

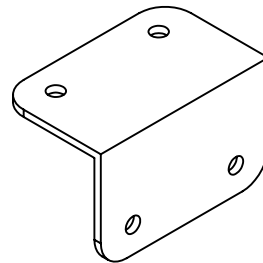

LANDING RAIL CORNER CLIP
2" x 2" x 1/8" THK x 3 1/4" LONG ANGLE
RTM PART#: PLRCNRANGL
QTY USED: 2

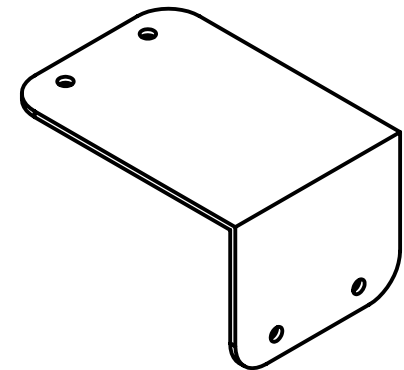

STAIR ATTACHMENT ANGLE BRACKET
2" x 5" x 1/8" THK x 4" LONG ANGLE
RTM PART#: PS2LANGLE
QTY USED: 2 PER STAIR

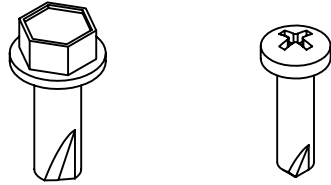

RAMP TO LANDING CONNECTION HARDWARE
(RTM PART#: R2LHDWE) (QTY INCLUDED: 1 BAG)

FOLLOWING ITEMS INCLUDED IN BAG:

HEX HEAD TEK SCREW (SELF-DRILLING)

#14 x 3/4" LONG

(QUANTITY: 5)

PAN HEAD TEK SCREW (SELF-DRILLING)

#10 x 3/4" LONG

(QUANTITY: 5)

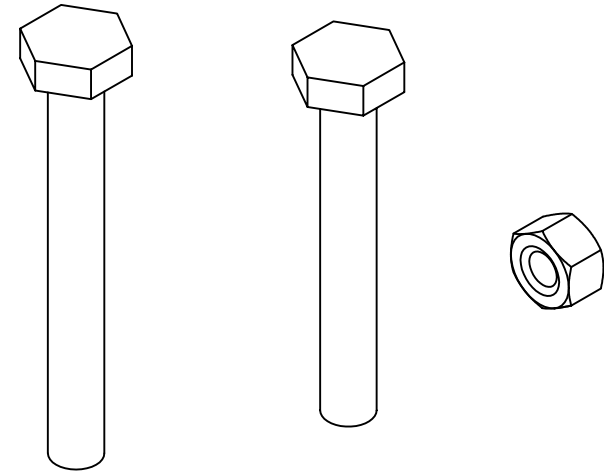

NEW STYLE LANDING LEG HARDWARE
(RTM PART#: NSLHDWE) (QTY INCLUDED: 1 BAG)

FOLLOWING ITEMS INCLUDED IN BAG:

HEX HEAD CAP SCREW (STAINLESS STEEL)

3/8" DIAMETER x 2 3/4" LONG

(QUANTITY: 4)

HEX HEAD CAP SCREW (STAINLESS STEEL)

3/8" DIAMETER x 3 1/4" LONG

(QUANTITY: 4)

3/8" HEX NUT (STAINLESS STEEL)

(QUANTITY: 8)

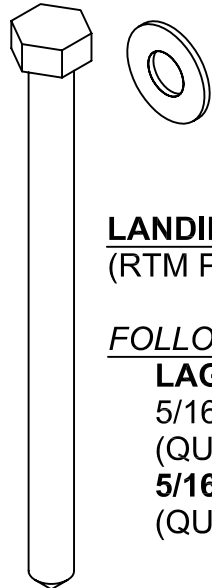

LANDING TO BUILDING CONNECTION HARDWARE
(RTM PART#: L2BHDWE) (QTY INCLUDED: 1 BAG)

FOLLOWING ITEMS INCLUDED IN BAG:

LAG BOLT (ZINC)

5/16" DIAMETER x 4 1/2" LONG

(QUANTITY: 4)

5/16" FLAT WASHER (STAINLESS STEEL)

(QUANTITY: 4)

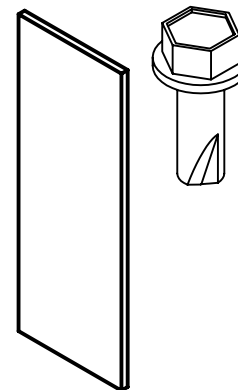

STAIR HARDWARE BAG
(RTM PART#:STHDWE4R OR STHDWE5R)
(QTY: 1 BAG DEPENDING ON STAIR)

FOLLOWING ITEMS INCLUDED IN BAG:

STAIR RAIL SHIM

0.090" x 2" PLATE, 4" LONG

(QUANTITY: 4)

HEX HEAD TEK SCREW (SELF-DRILLING)

#14 x 3/4" LONG

(QUANTITY FOR [STHDWE4R] 12)

(QUANTITY FOR [STHDWE5R] 16)

LANDING LEG ASSEMBLY

INSTRUCTIONS:

- A) Turn landing section upside down and place on level surface.
- B) Locate the landing leg cones, landing legs and landing leg assembly bag (for descriptions of parts, refer to page 5).
- C) Using (1) $\phi 3/8"$ x $2\ 3/4"$ long hex head cap screw and (1) $3/8"$ hex head nut, insert landing leg cone into receiver on underside of landing (as shown in picture). **TIGHTEN BOLT AND NUT SECURELY AT THIS TIME.**
- D) Measure threshold height at doorway.
- E) Adjust leg to appropriate height, measuring from the walking surface to the bottom side of the landing leg.
- F) Using (1) $\phi 3/8"$ x $3\ 1/4"$ long hex head cap screw and (1) $3/8"$ hex head nut, insert landing leg into landing leg cone (as shown in picture). **FINGER TIGHTEN NUT.** Adjustments to grade may be required later.

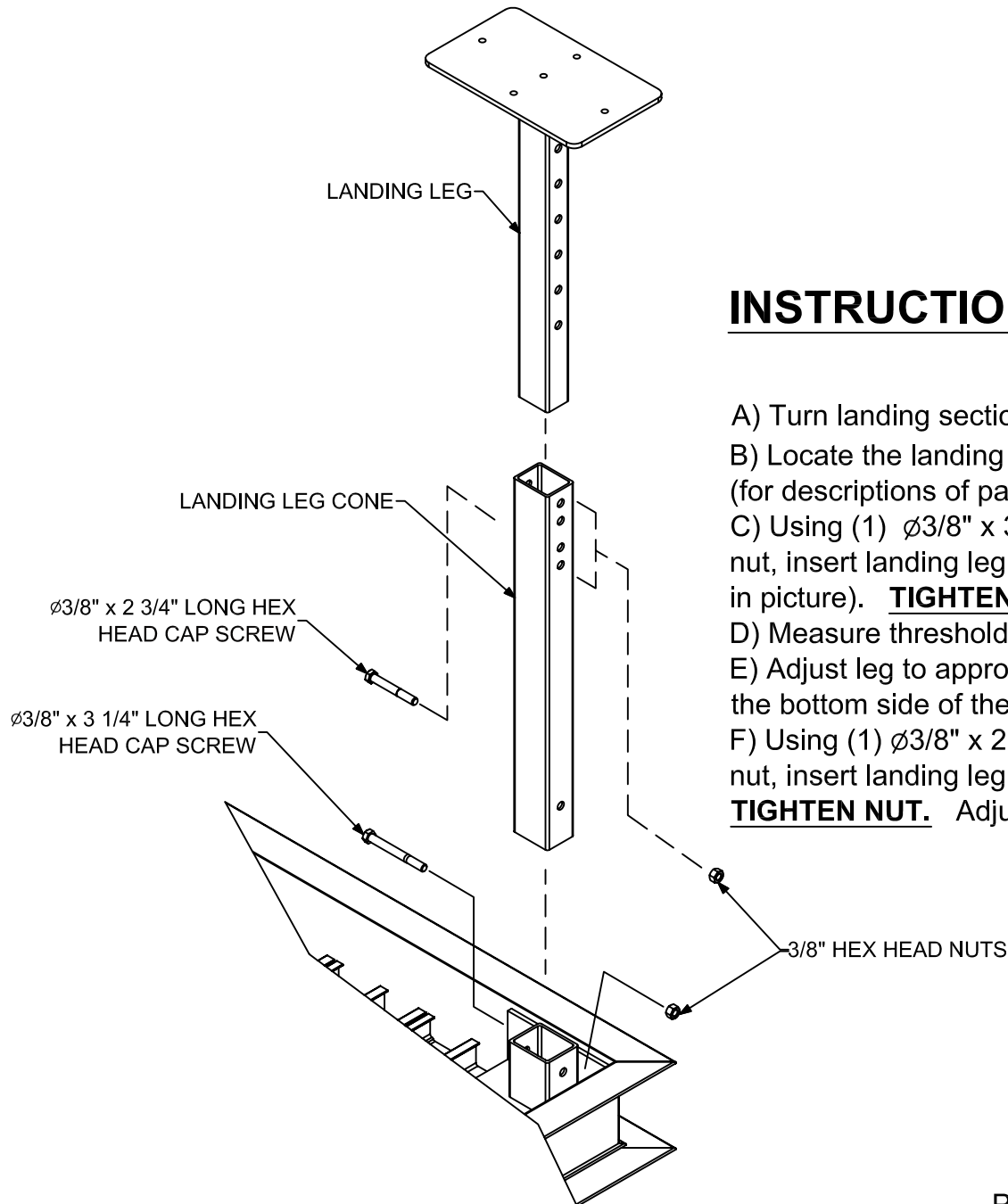

LANDING TO BUILDING ASSEMBLY

INSTRUCTIONS:

- A) Flip landing section over so that waking surface is facing up. Place angle side of landing towards building. A 2" to 4" space is needed on hinge side of door to allow for proper opening/closing of the door.
- B) Make sure landing is level. Adjust leg heights as needed. **ONCE LANDING IS LEVEL, SECURELY TIGHTEN REMAINING BOLTS ON LANDING LEGS.**
- C) Locate the landing to building hardware bag. (For descriptions of parts in bag refer to page 5).
- D) Using (4) $\text{Ø}5/16"$ x 4 1/2" long lag screws and (4) 5/16" flat washers, lag the landing into building (as shown in section view below).

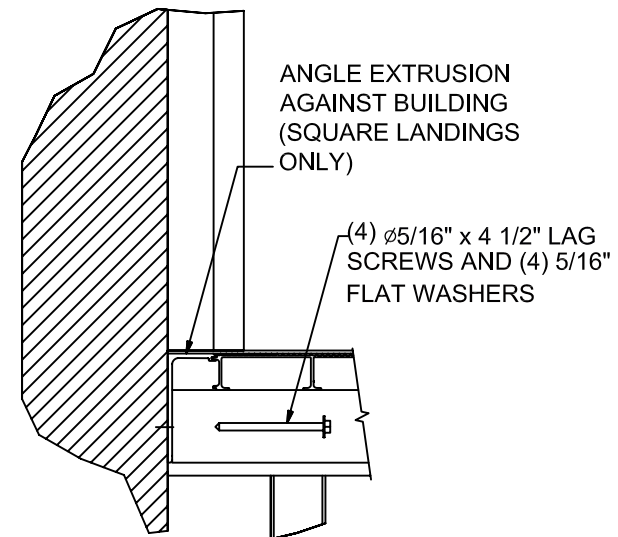
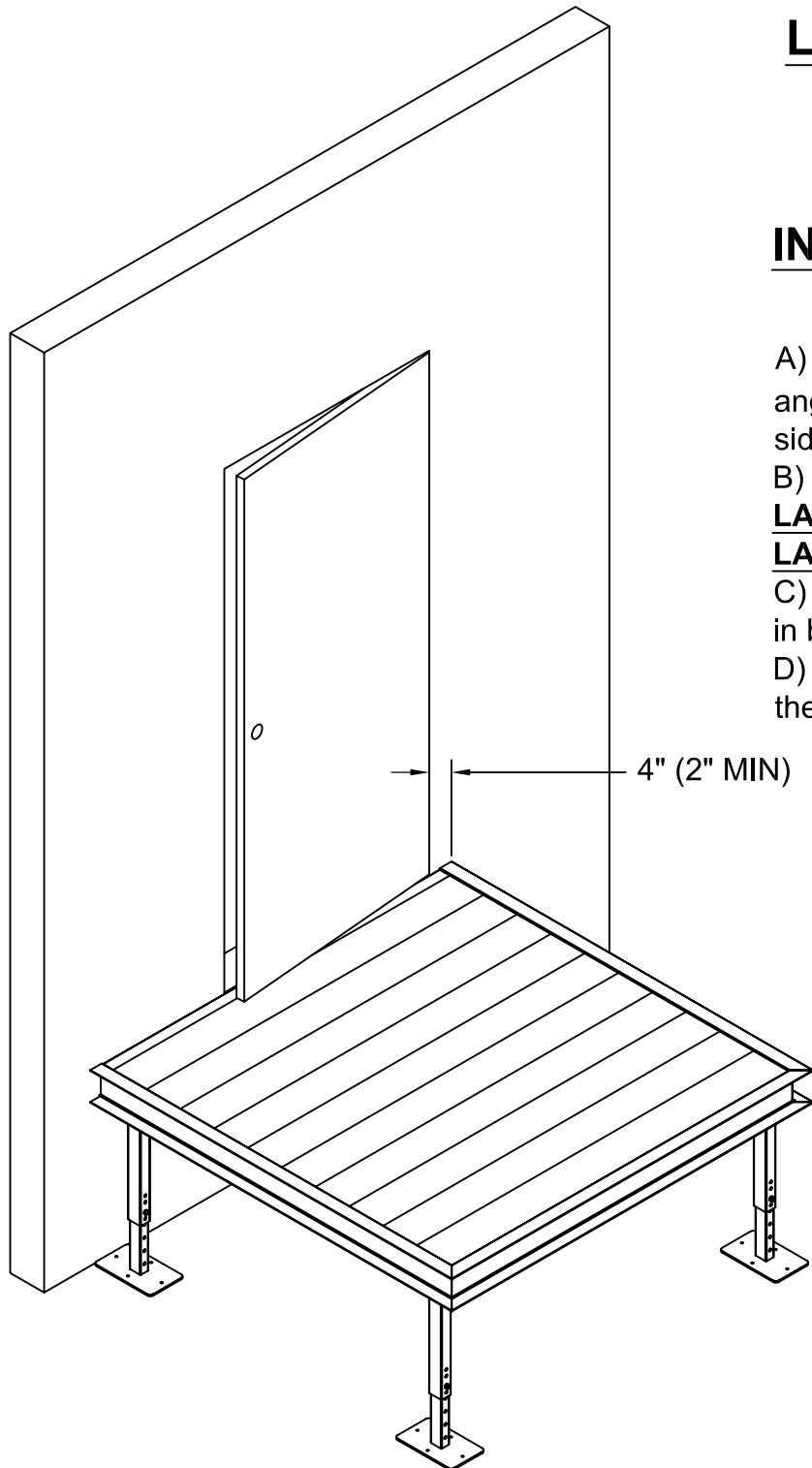

SECTION VIEW OF LANDING

LANDING RAIL INSTALLATION

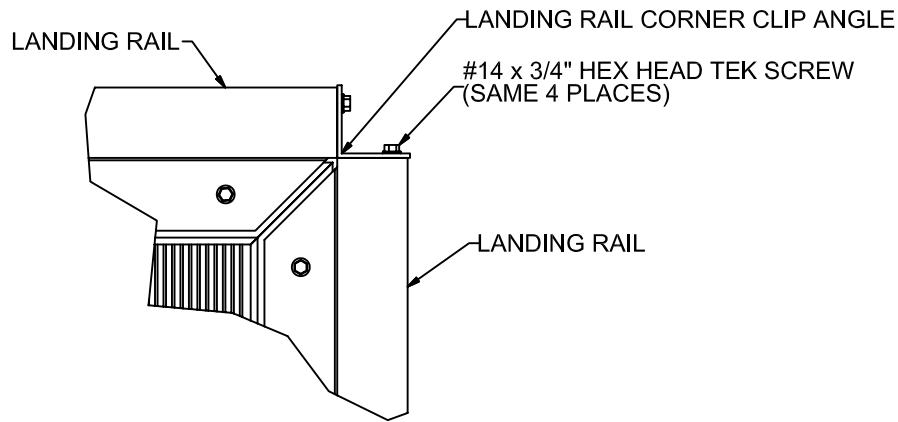

TOP VIEW OF RAIL
TO RAIL CONNECTION

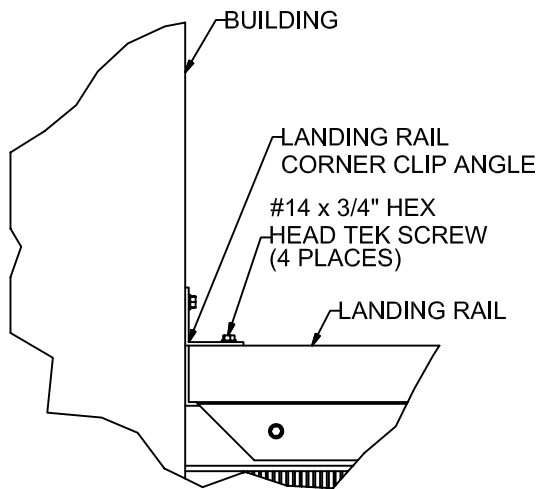

TOP VIEW OF RAIL
TO BUILDING CONNECTION

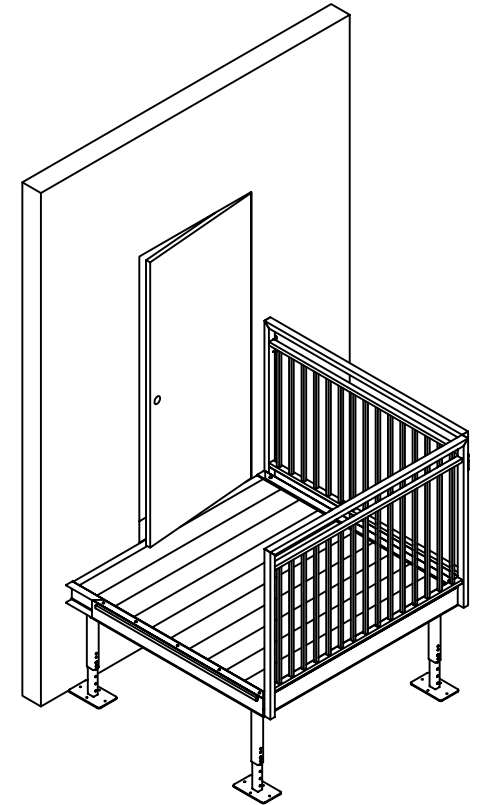

INSTRUCTIONS:

- A) Locate the 5'-0" landing rails. See Page 1 for description of parts.
 - B) Position one side of rail flush with outermost edge of landing (as shown in top view). Using a rubber mallet, secure rail to channel, making sure that rail is fully seated.
 - C) Attach rail to landing using #14 x 3/4" hex head Tek screws (found in bag of 120); drilling through pilot holes found on top of rail channel.
 - D) Secure bottom side of rail to landing channel using #14 x 3/4" hex head Tek screws (found in bag of 120). Space approximately the same distance apart as Tek head screws used on top side.
 - E) Align second 5'-0" rail to edge of landing opposite building or as required to accommodate your configuration (as shown in top view).
- REPEAT STEPS "B" AND "C" TO SECURE THE SECOND RAIL TO THE LANDING.**
- F) Secure both landing rails together using (1) landing rail corner clip and (4) #14 x 3/4" Tek head screws (see detail). Space landing rail corner clip approximately 6" from top of rail.
 - G) Secure other landing rail to building using (1) landing rail corner clip and (4) #14 x 3/4" Tek head screws (see detail). Space landing rail corner clip approximately 6" from top of rail.

STAIR TO REDD TEAM LANDING / STAIR TO EXISTING LANDING CONNECTION:

STAIR TO REDD TEAM LANDING:

- A) Position one side of stair channel flush with outermost edge of landing (as shown in top view). Using a rubber mallet, secure stair to channel, making sure that rail is fully seated.
- B) Attach TOP side of stair channel to landing using #14 x 3/4" hex head Tek screws (found in stair hardware bag); drilling through pilot holes found on top of rail channel.
- C) Secure BOTTOM side of stair channel to landing using #14 x 3/4" hex head Tek screws (found in stair hardware bag). Space approximately the same distance apart as Tek head screws used on top side.

STAIR TO EXISTING LANDING:

- A) Position blank channel 1/4" below threshold of existing landing.
- B) Connect blank channel to existing landing with hardware specified in detail view. Hardware for applications other than wood are not supplied by REDD Team, and must be purchased by others.

REPEAT STEPS ABOVE TO CONNECT CHANNEL TO EXISTING LANDING

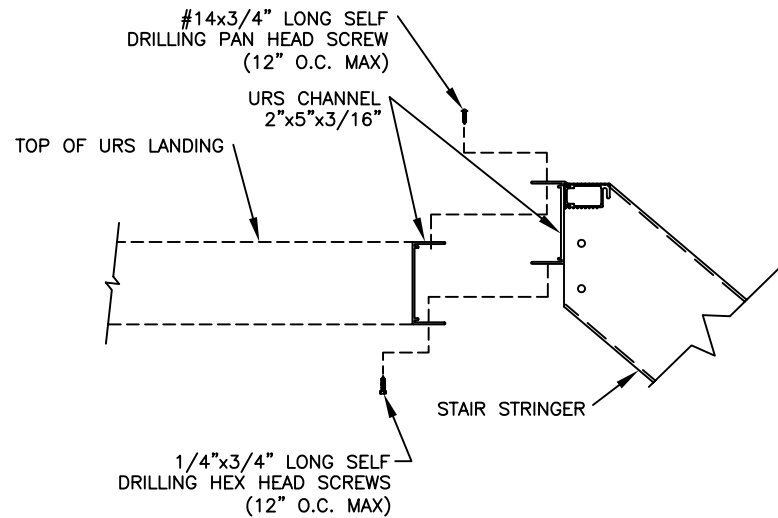

DETAIL A-A
STAIRWAY TO URS LANDING CONNECTION

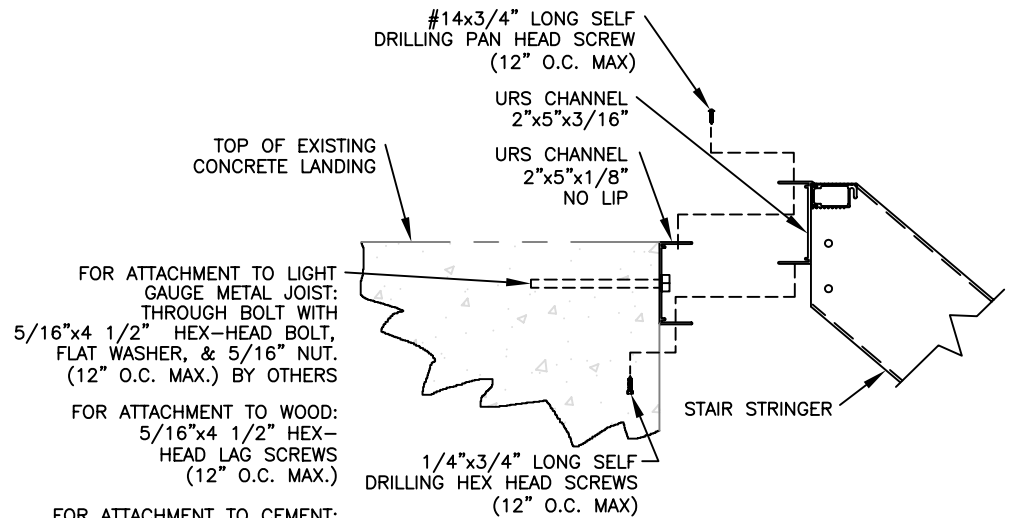

DETAIL B-B
STAIRWAY TO EXISTING LANDING CONNECTION

STAIR RAIL & MISC CONNECTION DETAILS

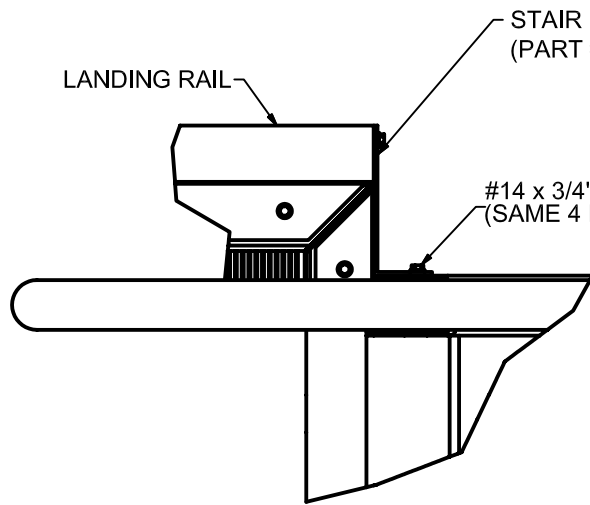

TOP VIEW OF STAIR RAIL CONNECTION

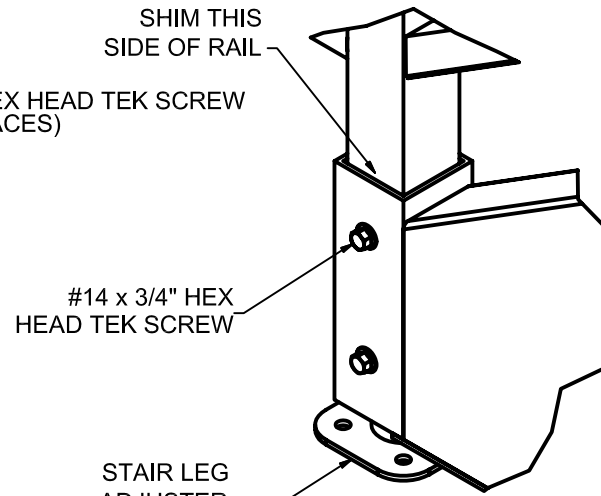

VIEW OF LEG ADJUSTER CONNECTION

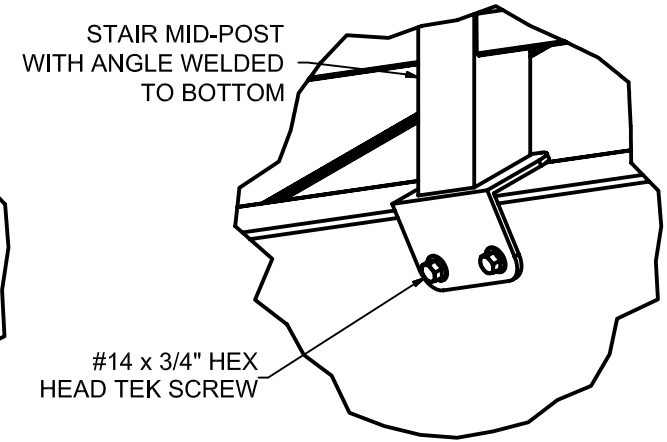

TOP VIEW OF STAIR RAIL MID-POST CONNECTION

INSTRUCTIONS:

STAIR RAIL TO STAIR STRINGER & STAIR ADJUSTER CONNECTION:

- A) Remove wooden shipping blocks from stair rail posts.
- B) Insert one stair rail into side of stair stringer, making sure that the handrail is facing towards the inside of the stair. The rail should bottom out on the top and bottom posts.

Note: You may have to insert the top post first, and wiggle back and forth to seat properly.

- C) Locate stair hardware bag (For description of parts, refer to page 3).
- D) Insert metal shim into outside of receiver tube. This is to prevent movement of rail. Repeat for upper end. (See detail).
- E) Insert stair leg adjuster into lower end of stair stringer. Level stair, making sure that the foot pad is resting on the ground. Repeat process for other side.

Note: If you are using a 6 riser stair, you must maintain 6" from the ground to the 1st tread.

If you are using a 7 riser stair, you must maintain 7" from the ground to the 1st tread.

- F) Secure stair rail & leg adjuster to stair bottom using #14 x 3/4" Hex Head Tek Screws.

OPTIONAL: Some stairs will have more than 2 posts on them. To secure the mid posts to the stair bottom, simply use (2) #14 X 3/4" Tek screws and secure the angle to the side of the stair stringer (see detail #). Repeat the process as needed.

STAIR RAIL TO LANDING RAIL CONNECTION:

- A) Secure stair rail to landing rail by using (1) stair rail corner clip (Part # PS2LANGLE) and (4) #14 x 3/4" Tek head screws (see detail). Space landing rail corner clip approximately 6" from top of rail. Repeat process for other side.