

PLAN VIEW: 38 VP/TL ALUMINUM ACCESS RAMP SYSTEM

NOTE: TO USE 38 VP or TL, MAX RUN OF ENTIRE RAMP SYSTEM CANNOT EXCEED 30'-0"

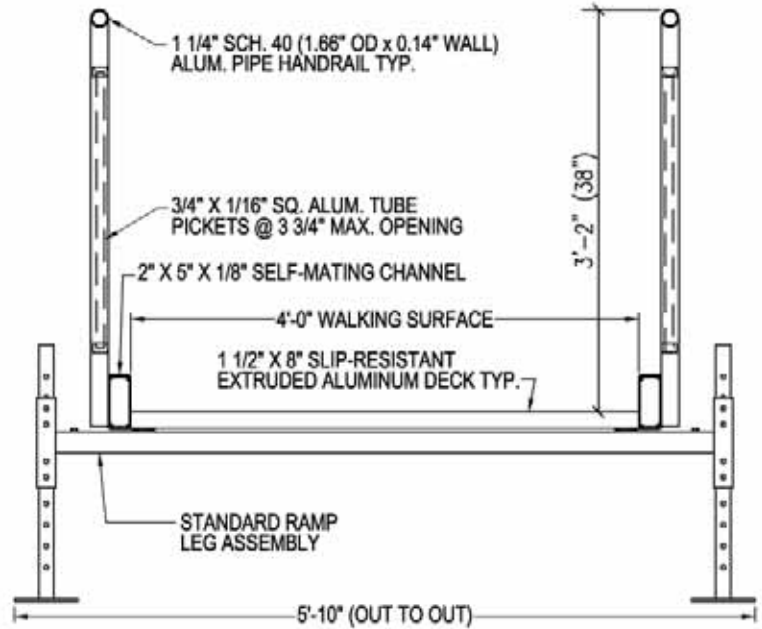

A-A  
1  
DETAIL  
38 VP/TL RAMP CROSS SECTION  
SCALE: 3/4" = 1'-0"

**GENERAL NOTES:**

1. ALUMINUM RAMP, LANDING AND STAIR SECTIONS SHALL BE A RIGID, FREE-SPAN DESIGN.
2. DESIGN OF THE ALUMINUM STRUCTURES SHALL CONFORM TO THE CURRENT EDITION OF THE ALUMINUM ASSOCIATION SPECIFICATIONS AND GUIDELINES FOR ALUMINUM STRUCTURES.
3. ALL ALUMINUM CONSTRUCTION USING 6000 SERIES ALUMINUM ALLOYS. STRUCTURAL MEMBERS TO BE 6061-T6 AND 6063-T6 ALUMINUM ALLOY.
4. ALUMINUM WILL BE STANDARD MILL FINISH UNLESS OTHERWISE NOTED.
5. WELDING SHALL BE IN ACCORDANCE WITH ANSI/AWS D1.2-97 GAS METAL ARC WELDING (GMAW) PROCESS BY EXPERIENCED OPERATORS.
6. ALL FASTENERS TO BE 18-8 (SERIES 304) STAINLESS STEEL UNLESS OTHERWISE NOTED.
7. LANDING, RAMP AND STAIR SECTIONS ARE TO BE ENGINEERED FOR A 100 PSF LIVE LOAD.
8. LANDING AND RAMP WALKING SURFACES SHALL BE DESIGNED FOR A MINIMUM CONCENTRATED VERTICAL LOAD OF 300 LBS APPLIED EVENLY OVER A 12" x 12" AREA. STAIR TREAD SHALL BE DESIGNED FOR A MINIMUM CONCENTRATED VERTICAL LOAD OF 300 LBS APPLIED EVENLY OVER A 4 INCH SQUARE AREA.
9. RAMP AND LANDING GUARDRAILS TO BE 42 INCH MINIMUM HEIGHT UNLESS OTHERWISE SPECIFIED. (34 AND 38 INCH TWO-LINE RAMP RAILS AND 34 AND 38 INCH VERTICAL PICKET RAMP RAILS AS WELL AS CUSTOM DESIGN RAMP RAILS AVAILABLE UPON REQUEST FOR SYSTEMS NO MORE THAN 30 INCHES ABOVE FINISHED GROUND LEVEL.)
10. GUARDRAILS SHALL BE DESIGNED AND CONSTRUCTED FOR A LOAD OF 50 PLF APPLIED HORIZONTALLY AT THE REQUIRED GUARDRAIL HEIGHT AND A SIMULTANEOUS LOAD OF 100 PLF APPLIED VERTICALLY DOWNWARD AT THE TOP OF THE GUARDRAIL.
11. HANDRAILS SHALL BE DESIGNED AND CONSTRUCTED FOR A LOAD OF 50 PLF APPLIED IN ANY DIRECTION.
12. HANDRAILS AND GUARDRAILS SHALL BE DESIGNED FOR A CONCENTRATED LOAD OF 200 LB APPLIED AT ANY POINT AND IN ANY DIRECTION.
13. GUARDRAILS SHALL BE DESIGNED SO THAT A 4 (FOUR) INCH SPHERE CANNOT PASS THROUGH ANY OPENING IN THE RAIL.
14. DECK SURFACE SHALL BE A SLIP RESISTANT, EXTRUDED ALUMINUM DECKING WITH A TRIPLE I-BEAM, SELF-MATING DESIGN.
15. ALL SURFACES, MEMBERS AND THEIR WELDED JOINTS SHALL BE SMOOTH AND FREE FROM SHARP OR JAGGED EDGES.
16. ALL DESIGNS SHOWN HEREIN ARE SUBJECT TO CHANGE PENDING FIELD VERIFICATION OF EXISTING CONDITIONS.

ALUMINUM ACCESS RAMP SYSTEM  
W.L. HALL & ASSOCIATES, INC.  
DESIGNER  
11000 W. PARKWAY, SUITE 100  
MIRAGE, FLORIDA 32856  
PHONE: (407) 251-1111  
FAX: (407) 251-1112

REDD Team Manufacturing,  
A Division of Alcoa Extrusions, Inc.  
6599 S.R. 21  
Koyotee Heights, Florida 32856  
Phone: (1800)948-3888 Fax: (1800)943-0218



FOR QUOTE  
PURPOSES ONLY

UNIVERSAL RAMP SYSTEM  
ALUMINUM ACCESS RAMP SYSTEM  
WITH 38VP VERTICAL PICKET GUARD RAILS

2004  
SALES URS  
SALES URS  
PLM  
SHEET NUMBER  
88VP-INT-



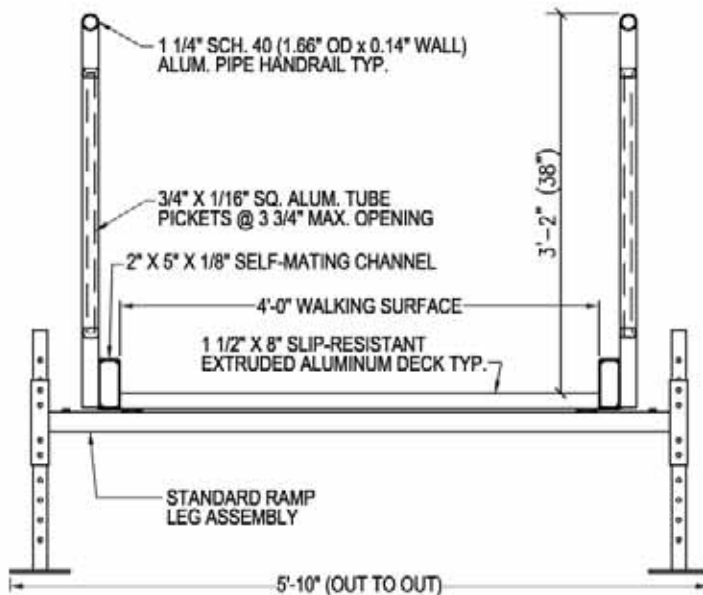
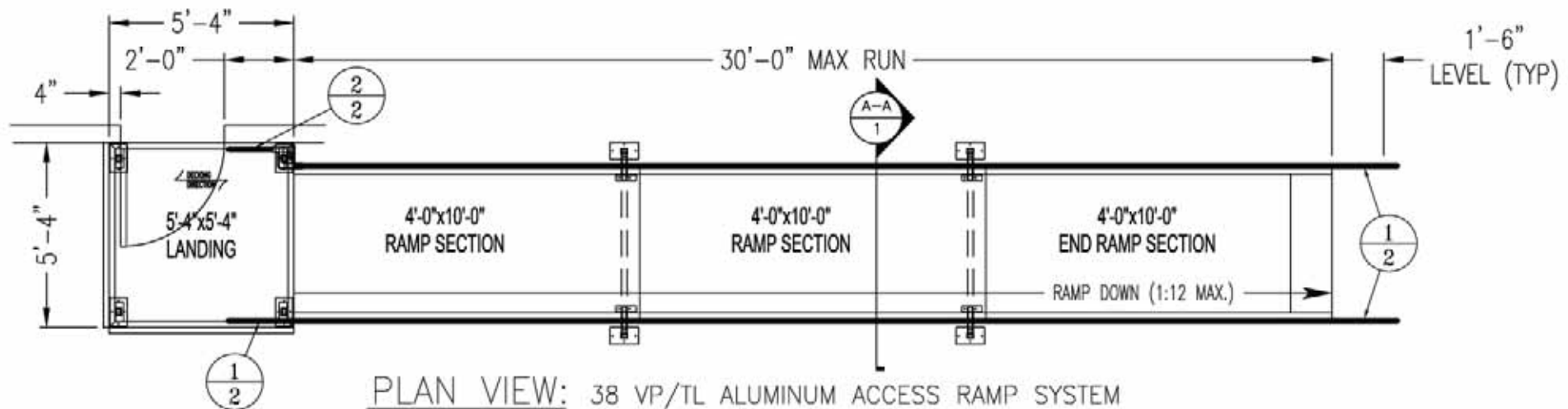

A-A 1  
**DETAIL**  
 38" VP/TL RAMP CROSS SECTION  
 SCALE: 3/4" = 1'-0"

**GENERAL NOTES:**

1. ALUMINUM RAMP, LANDING AND STAIR SECTIONS SHALL BE A RIGID, FREE-SPAN DESIGN.
2. DESIGN OF THE ALUMINUM STRUCTURES SHALL CONFORM TO THE CURRENT EDITION OF **THE ALUMINUM ASSOCIATION SPECIFICATIONS AND GUIDELINES FOR ALUMINUM STRUCTURES**.
3. ALL ALUMINUM CONSTRUCTION USING 6000 SERIES ALUMINUM ALLOYS. STRUCTURAL MEMBERS TO BE 6061-T6 AND 6063-T6 ALUMINUM ALLOY.
4. ALUMINUM WILL BE STANDARD MILL FINISH UNLESS OTHERWISE NOTED.
5. WELDING SHALL BE IN ACCORDANCE WITH ANSI/AWS D1.2-97 GAS METAL ARC WELDING (GMAW) PROCESS BY EXPERIENCED OPERATORS.
6. ALL FASTENERS TO BE 18-8 (SERIES 304) STAINLESS STEEL UNLESS OTHERWISE NOTED.
7. LANDING, RAMP AND STAIR SECTIONS ARE TO BE ENGINEERED FOR A 100 PSF LIVE LOAD.
8. LANDING AND RAMP WALKING SURFACES SHALL BE DESIGNED FOR A MINIMUM CONCENTRATED VERTICAL LOAD OF 300 LBS APPLIED EVENLY OVER A 12" x 12" AREA. STAIR TREAD SHALL BE DESIGNED FOR A MINIMUM CONCENTRATED VERTICAL LOAD OF 300 LBS APPLIED EVENLY OVER A 4 INCH SQUARE AREA.
9. RAMP AND LANDING GUARDRAILS TO BE 42 INCH MINIMUM HEIGHT UNLESS OTHERWISE SPECIFIED. (34 AND 38 INCH TWO-LINE RAMP RAILS AND 34 AND 38 INCH VERTICAL PICKET RAMP RAILS AS WELL AS CUSTOM DESIGN RAMP RAILS AVAILABLE UPON REQUEST FOR SYSTEMS NO MORE THAN 30 INCHES ABOVE FINISHED GROUND LEVEL.)
10. GUARDRAILS SHALL BE DESIGNED AND CONSTRUCTED FOR A LOAD OF 50 PLF APPLIED HORIZONTALLY AT THE REQUIRED GUARDRAIL HEIGHT AND A SIMULTANEOUS LOAD OF 100 PLF APPLIED VERTICALLY DOWNWARD AT THE TOP OF THE GUARDRAIL.
11. HANDRAILS SHALL BE DESIGNED AND CONSTRUCTED FOR A LOAD OF 50 PLF APPLIED IN ANY DIRECTION.
12. HANDRAILS AND GUARDRAILS SHALL BE DESIGNED FOR A CONCENTRATED LOAD OF 200 LB APPLIED AT ANY POINT AND IN ANY DIRECTION.
13. GUARDRAILS SHALL BE DESIGNED SO THAT A 4 (FOUR) INCH SPHERE CANNOT PASS THROUGH ANY OPENING IN THE RAIL.
14. DECK SURFACE SHALL BE A SLIP RESISTANT, EXTRUDED ALUMINUM DECKING WITH A TRIPLE I-BEAM, SELF-MATING DESIGN.
15. ALL SURFACES, MEMBERS AND THEIR WELDED JOINTS SHALL BE SMOOTH AND FREE FROM SHARP OR JAGGED EDGES.
16. ALL DESIGNS SHOWN HEREIN ARE SUBJECT TO CHANGE PENDING FIELD VERIFICATION OF EXISTING CONDITIONS.

ALUMINUM ACCESS RAMP SYSTEM  
 A Division of Alcoa Extrusions, Inc.  
 6599 S.R. 21  
 Keyport Heights, Florida 32856  
 Phone: (1-800)948-3868 Fax: (1-800)943-0218

REDD Team Manufacturing  
 A Division of Alcoa Extrusions, Inc.  
 6599 S.R. 21  
 Keyport Heights, Florida 32856  
 Phone: (1-800)948-3868 Fax: (1-800)943-0218

REDD Team Manufacturing

FOR QUOTE PURPOSES ONLY

UNIVERSAL RAMP SYSTEM  
 ALUMINUM ACCESS RAMP SYSTEM  
 WITH 38" VERTICAL PICKET GUARD RAILS

2004  
 SALES URS  
 SALES URS  
 PLM  
 SHEET NUMBER  
 38-ST-1

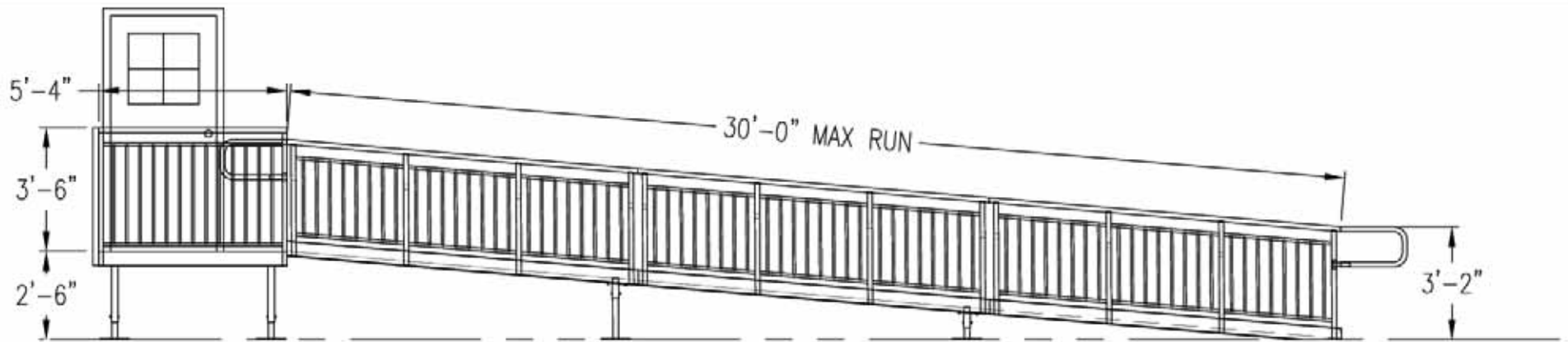

ELEVATION VIEW: 38 VP/TL ALUMINUM ACCESS RAMP SYSTEM

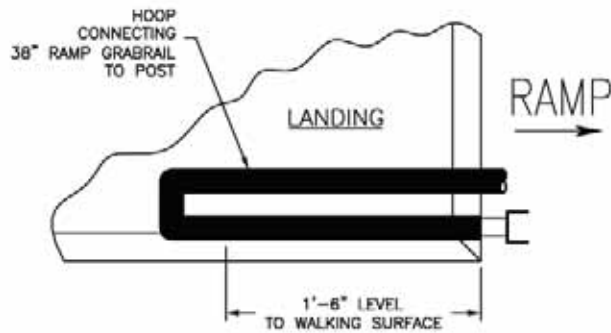

1 UPPER/LOWER HOOP DETAIL  
2 38VP RAMP HANDRAIL

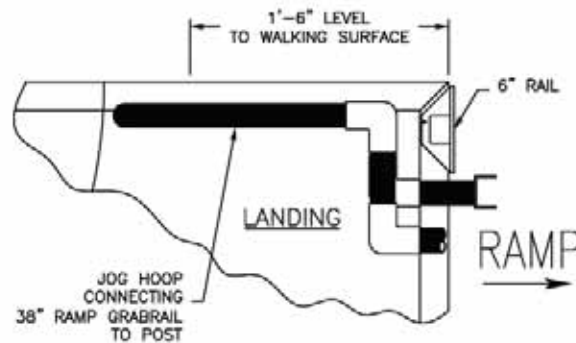

2 UPPER JOG HOOP DETAIL  
2 38VP RAMP HANDRAIL

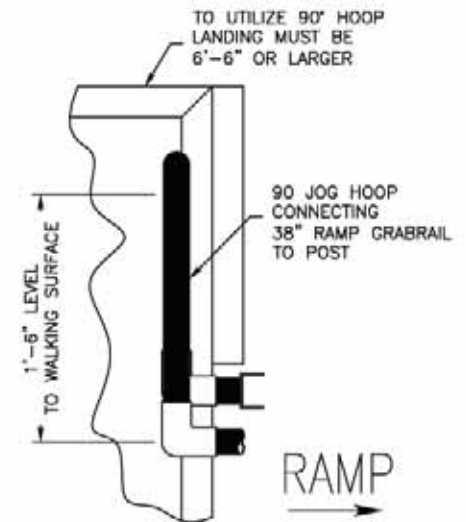

3 UPPER 90° HOOP DETAIL  
2 38VP RAMP HANDRAIL (OPTIONAL)

ALUMINUM RAMP SYSTEMS  
W.L.T. MADE BY PERFORMING IN  
ALUMINUM RAMP SYSTEMS  
W.L.T. MADE BY PERFORMING IN  
ALUMINUM RAMP SYSTEMS  
W.L.T. MADE BY PERFORMING IN

REDD Team Manufacturing,  
A Division of Alcoa Extrusions, Inc.  
6599 S.R. 21  
Koyotee Heights, Florida 32856  
Phone: 1-800-948-3868 Fax: 1-850-473-0218



FOR QUOTE  
PURPOSES ONLY

UNIVERSAL RAMP SYSTEM  
ALUMINUM ACCESS RAMP SYSTEM  
WITH 38VP VERTICAL POCKET GUARD RAILS

2004  
SALES URS  
SALES URS  
PLM  
SHEET NUMBER  
38VP-ST-2

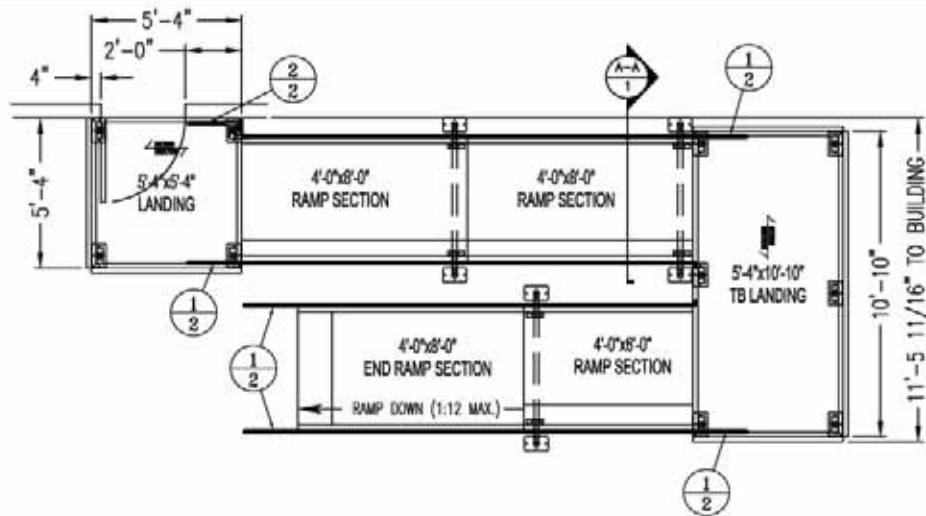

## PLAN VIEW: 38 VP/TL ALUMINUM ACCESS RAMP SYSTEM

NOTE: TO USE 38 VP or TL, MAX RUN OF ENTIRE RAMP SYSTEM CANNOT EXCEED 30'-0"

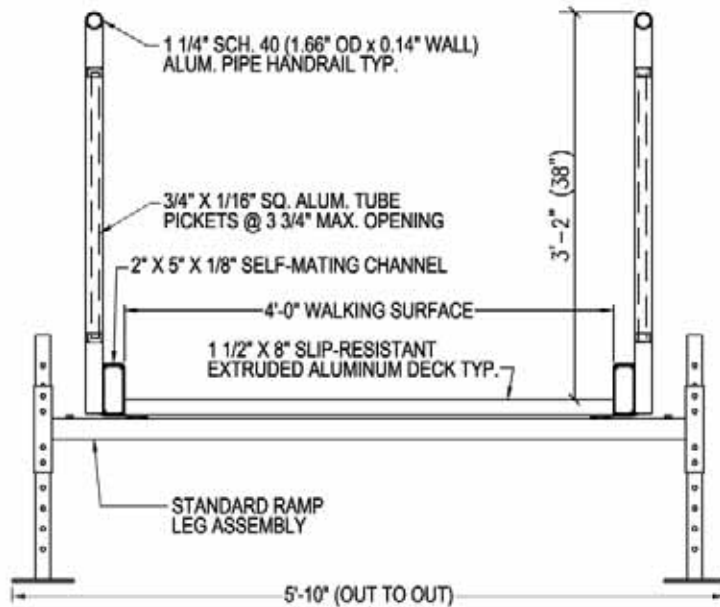

**A-A**  
**1** **DETAIL**  
38" VP/TL RAMP CROSS SECTION  
SCALE: 3/4" = 1'-0"

### GENERAL NOTES:

- ALUMINUM RAMP, LANDING AND STAIR SECTIONS SHALL BE A RIGID, FREE-SPAN DESIGN.
- DESIGN OF THE ALUMINUM STRUCTURES SHALL CONFORM TO THE CURRENT EDITION OF **THE ALUMINUM ASSOCIATION SPECIFICATIONS AND GUIDELINES FOR ALUMINUM STRUCTURES**.
- ALL ALUMINUM CONSTRUCTION USING 6000 SERIES ALUMINUM ALLOYS. STRUCTURAL MEMBERS TO BE 6061-T6 AND 6063-T6 ALUMINUM ALLOY.
- ALUMINUM WILL BE STANDARD MILL FINISH UNLESS OTHERWISE NOTED.
- WELDING SHALL BE IN ACCORDANCE WITH ANSI/AWS D1.2-97 GAS METAL ARC WELDING (GMAW) PROCESS BY EXPERIENCED OPERATORS.
- ALL FASTENERS TO BE 18-8 (SERIES 304) STAINLESS STEEL UNLESS OTHERWISE NOTED.
- LANDING, RAMP AND STAIR SECTIONS ARE TO BE ENGINEERED FOR A 100 PSF LIVE LOAD.
- LANDING AND RAMP WALKING SURFACES SHALL BE DESIGNED FOR A MINIMUM CONCENTRATED VERTICAL LOAD OF 300 LBS APPLIED EVENLY OVER A 12" x 12" AREA. STAIR TREAD SHALL BE DESIGNED FOR A MINIMUM CONCENTRATED VERTICAL LOAD OF 300 LBS APPLIED EVENLY OVER A 4 INCH SQUARE AREA.
- RAMP AND LANDING GUARDRAILS TO BE 42 INCH MINIMUM HEIGHT UNLESS OTHERWISE SPECIFIED. (34 AND 38 INCH TWO-LINE RAMP RAILS AND 34 AND 38 INCH VERTICAL PICKET RAMP RAILS AS WELL AS CUSTOM DESIGN RAMP RAILS AVAILABLE UPON REQUEST FOR SYSTEMS NO MORE THAN 30 INCHES ABOVE FINISHED GROUND LEVEL.)
- GUARDRAILS SHALL BE DESIGNED AND CONSTRUCTED FOR A LOAD OF 50 PLF APPLIED HORIZONTALLY AT THE REQUIRED GUARDRAIL HEIGHT AND A SIMULTANEOUS LOAD OF 100 PLF APPLIED VERTICALLY DOWNWARD AT THE TOP OF THE GUARDRAIL.
- HANDRAILS SHALL BE DESIGNED AND CONSTRUCTED FOR A LOAD OF 50 PLF APPLIED IN ANY DIRECTION.
- HANDRAILS AND GUARDRAILS SHALL BE DESIGNED FOR A CONCENTRATED LOAD OF 200 LB APPLIED AT ANY POINT AND IN ANY DIRECTION.
- GUARDRAILS SHALL BE DESIGNED SO THAT A 4 (FOUR) INCH SPHERE CANNOT PASS THROUGH ANY OPENING IN THE RAIL.
- DECK SURFACE SHALL BE A SLIP RESISTANT, EXTRUDED ALUMINUM DECKING WITH A TRIPLE I-BEAM, SELF-MATING DESIGN.
- ALL SURFACES, MEMBERS AND THEIR WELDED JOINTS SHALL BE SMOOTH AND FREE FROM SHARP OR JAGGED EDGES.
- ALL DESIGNS SHOWN HEREIN ARE SUBJECT TO CHANGE PENDING FIELD VERIFICATION OF EXISTING CONDITIONS.

EXISTING LAMP STRUCTURE NOT SHOWN  
WALLS AND FLOORING TO BE  
REMOVED AND RECONSTRUCTED  
AS SHOWN ON SHEET 38VP-TB-1  
WALLS, FLOORING, CEILING, AND  
STRUCTURES TO BE RECONSTRUCTED  
AS SHOWN ON SHEET 38VP-TB-2

REDD Team Manufacturing,  
A Division of Alcoa Extrusions, Inc.  
6599 S.R. 21  
Koyotee Heights, Florida 32856  
Phone: 1-800-948-3868 Fax: 1-800-948-0218

REDD  
Team  
Manufacturing

FOR QUOTE  
PURPOSES ONLY

UNIVERSAL RAMP SYSTEM  
ALUMINUM ACCESS RAMP SYSTEM  
WITH 38VP VERTICAL PICKET GUARD RAILS

DATE: 2004  
BY: SALES URS  
CHECKED: SALES URS  
DESIGNED BY: PLM  
PROJECT #:  
SHEET NUMBER  
38VP-TB-

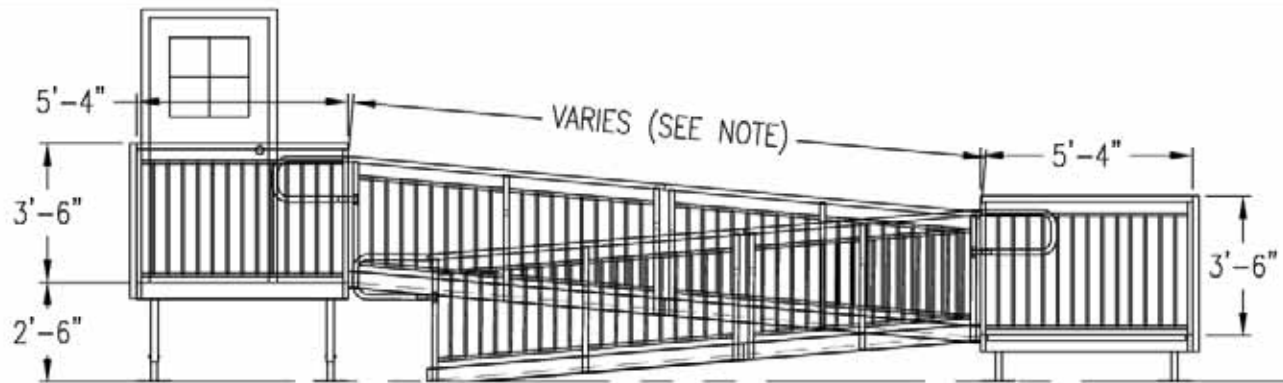

ELEV VIEW: 38 VP/TL ALUMINUM ACCESS RAMP SYSTEM  
 NOTE: TO USE 38 VP/TL, MAX RUN OF RAMP SYSTEM=30'-0"

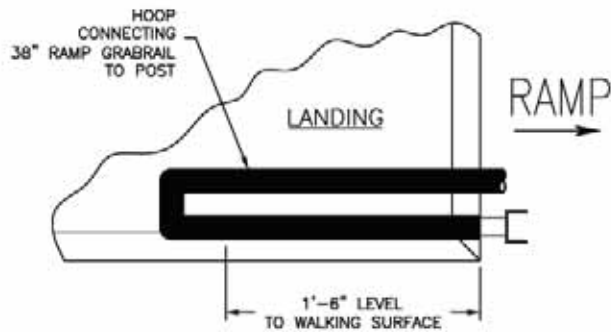

1 UPPER/LOWER HOOP DETAIL  
 2 38VP RAMP HANDRAIL

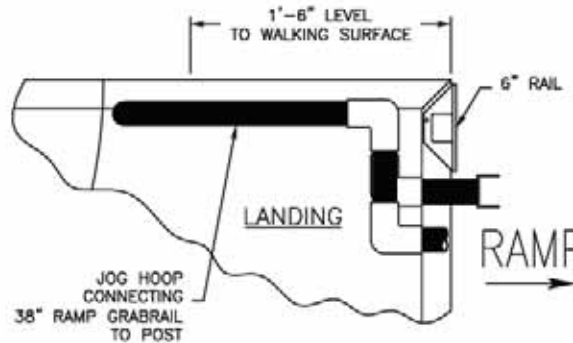

2 UPPER JOG HOOP DETAIL  
 2 38VP RAMP HANDRAIL

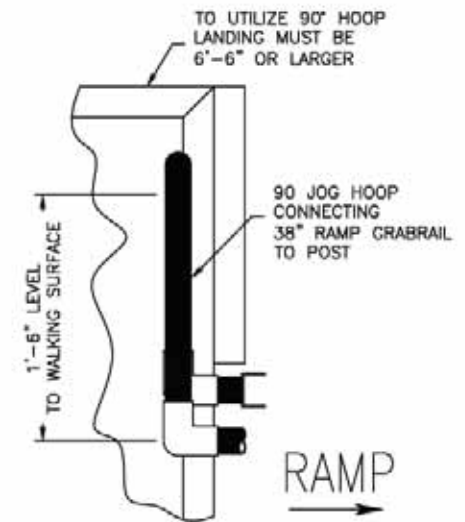

3 UPPER 90 degree HOOP DETAIL  
 2 38VP RAMP HANDRAIL (OPTIONAL)

ALUMINUM RAMP SYSTEM  
 UNIVERSAL ACCESS RAMP SYSTEM  
 WITH 38VP VERTICAL POCKET GUARD RAILS

REDD Team Manufacturing,  
 A Division of Alcoa Extrusions, Inc.  
 6599 S.R. 21  
 KeySTONE Heights, Florida 32856  
 Phone: 1(800)948-3868 Fax: 1(352)473-0218



FOR QUOTE  
 PURPOSES ONLY

UNIVERSAL RAMP SYSTEM  
 ALUMINUM ACCESS RAMP SYSTEM  
 WITH 38VP VERTICAL POCKET GUARD RAILS

2004  
 SALES URS  
 SALES URS

PLM

SHEET NUMBER  
 38VP-TD-2

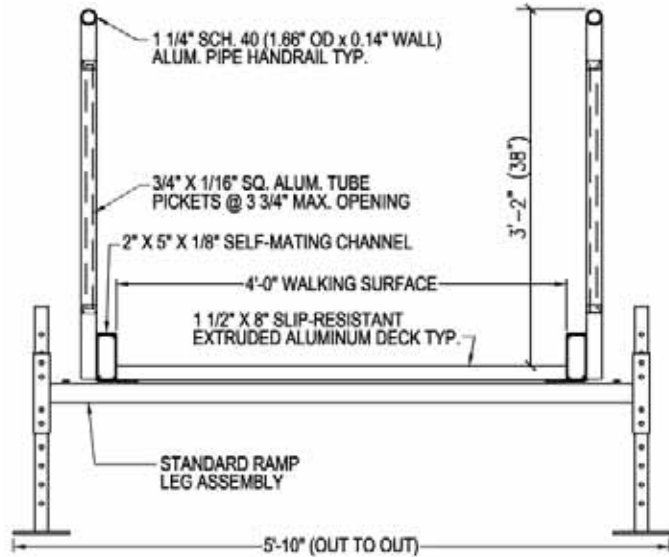
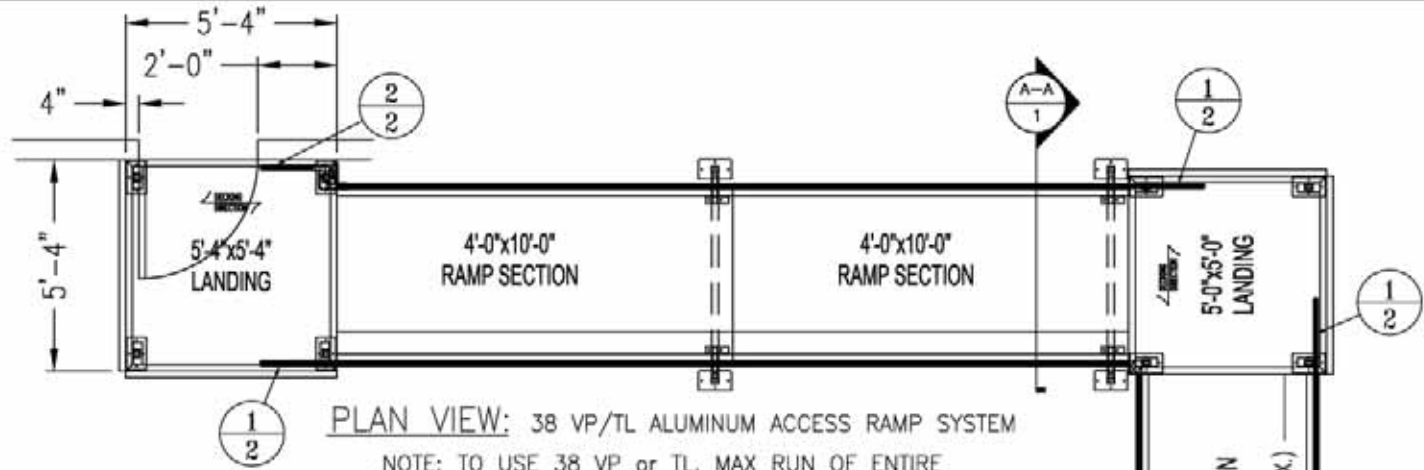

#### GENERAL NOTES:

1. ALUMINUM RAMP, LANDING AND STAIR SECTIONS SHALL BE A RIGID, FREE-SPAN DESIGN.
2. DESIGN OF THE ALUMINUM STRUCTURES SHALL CONFORM TO THE CURRENT EDITION OF **THE ALUMINUM ASSOCIATION SPECIFICATIONS AND GUIDELINES FOR ALUMINUM STRUCTURES**.
3. ALL ALUMINUM CONSTRUCTION USING 6000 SERIES ALUMINUM ALLOYS. STRUCTURAL MEMBERS TO BE 6061-T8 AND 6063-T8 ALUMINUM ALLOY.
4. ALUMINUM WILL BE STANDARD MILL FINISH UNLESS OTHERWISE NOTED.
5. WELDING SHALL BE IN ACCORDANCE WITH ANSI/AWS D1.2-97 GAS METAL ARC WELDING (GMAW) PROCESS BY EXPERIENCED OPERATORS.
6. ALL FASTENERS TO BE 18-8 (SERIES 304) STAINLESS STEEL UNLESS OTHERWISE NOTED.
7. LANDING, RAMP AND STAIR SECTIONS ARE TO BE ENGINEERED FOR A 100 PSF LIVE LOAD.
8. LANDING AND RAMP WALKING SURFACES SHALL BE DESIGNED FOR A MINIMUM CONCENTRATED VERTICAL LOAD OF 300 LBS APPLIED EVENLY OVER A 12" x 12" AREA. STAIR TREAD SHALL BE DESIGNED FOR A MINIMUM CONCENTRATED VERTICAL LOAD OF 300 LBS APPLIED EVENLY OVER A 4 INCH SQUARE AREA.
9. RAMP AND LANDING GUARDRAILS TO BE 42 INCH MINIMUM HEIGHT UNLESS OTHERWISE SPECIFIED. (34 AND 38 INCH TWO-LINE RAMP RAILS AND 34 AND 38 INCH VERTICAL PICKET RAMP RAILS AS WELL AS CUSTOM DESIGN RAMP RAILS AVAILABLE UPON REQUEST FOR SYSTEMS NO MORE THAN 30 INCHES ABOVE FINISHED GROUND LEVEL.)
10. GUARDRAILS SHALL BE DESIGNED AND CONSTRUCTED FOR A LOAD OF 50 PLF APPLIED HORIZONTALLY AT THE REQUIRED GUARDRAIL HEIGHT AND A SIMULTANEOUS LOAD OF 100 PLF APPLIED VERTICALLY DOWNWARD AT THE TOP OF THE GUARDRAIL.
11. HANDRAILS SHALL BE DESIGNED AND CONSTRUCTED FOR A LOAD OF 50 PLF APPLIED IN ANY DIRECTION.
12. HANDRAILS AND GUARDRAILS SHALL BE DESIGNED FOR A CONCENTRATED LOAD OF 200 LB APPLIED AT ANY POINT AND IN ANY DIRECTION.
13. GUARDRAILS SHALL BE DESIGNED SO THAT A 4 (FOUR) INCH SPHERE CANNOT PASS THROUGH ANY OPENING IN THE RAIL.
14. DECK SURFACE SHALL BE A SLIP RESISTANT, EXTRUDED ALUMINUM DECKING WITH A TRIPLE I-BEAM, SELF-MATING DESIGN.
15. ALL SURFACES, MEMBERS AND THEIR WELDED JOINTS SHALL BE SMOOTH AND FREE FROM SHARP OR JAGGED EDGES.
16. ALL DESIGNS SHOWN HEREIN ARE SUBJECT TO CHANGE PENDING FIELD VERIFICATION OF EXISTING CONDITIONS.

UNIVERSAL RAMP SYSTEM  
ALUMINUM ACCESS RAMP SYSTEM  
WITH 38VP VERTICAL PICKET GUARD RAILS

REDD Team Manufacturing, Inc.  
A Division of Alcoa Extrusions, Inc.  
6599 S.R. 21  
Koyotee Heights, Florida 32856  
Phone: 1-800-948-3868 Fax: 1-352-473-0215

FOR QUOTE  
PURPOSES ONLY

UNIVERSAL RAMP SYSTEM  
ALUMINUM ACCESS RAMP SYSTEM  
WITH 38VP VERTICAL PICKET GUARD RAILS

2004  
SALES URS  
SALES URS  
FLM  
SHEET NUMBER  
38VP-90-

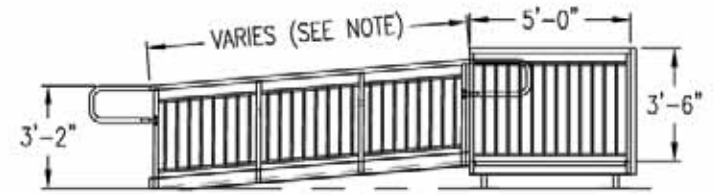
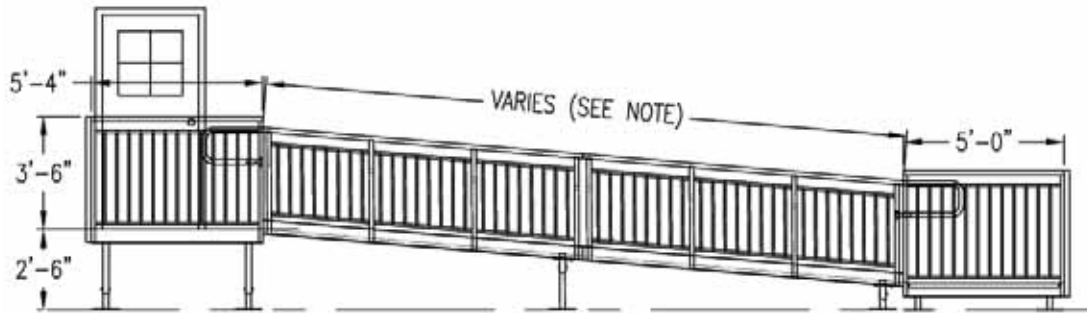

ELEV VIEW: 38 VP/TL ALUMINUM ACCESS RAMP SYSTEM  
 NOTE: TO USE 38 VP/TL, MAX RUN OF RAMP SYSTEM=30'-0"

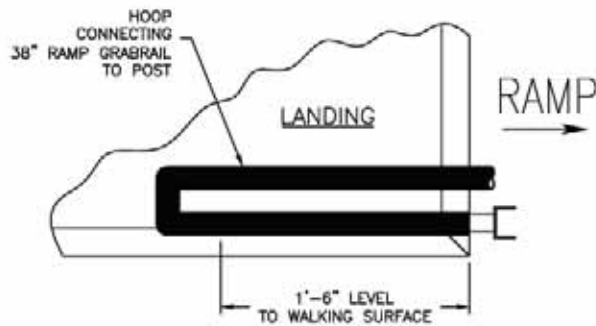

1 UPPER/LOWER HOOP DETAIL  
 2 38VP RAMP HANDRAIL

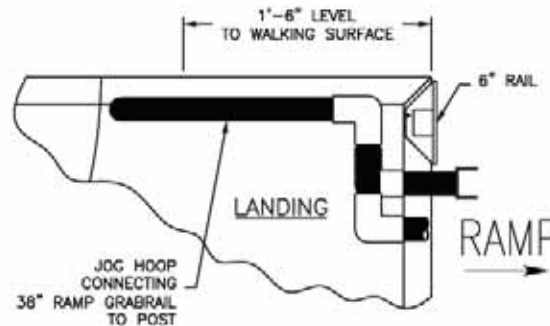

2 UPPER JOG HOOP DETAIL  
 2 38VP RAMP HANDRAIL

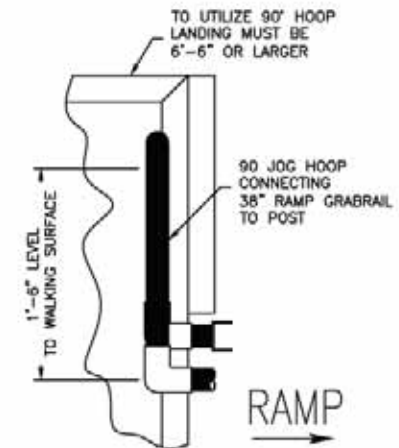

3 UPPER 90° HOOP DETAIL  
 2 38VP RAMP HANDRAIL (OPTIONAL)

SEE LISTING FOR SPECIFICATIONS AND MATERIALS. ALL DIMENSIONS ARE IN INCHES UNLESS OTHERWISE NOTED. THIS DRAWING IS THE PROPERTY OF REDD TEAM MANUFACTURING, INC. AND IS TO BE USED ONLY FOR THE PROJECT AND LOCATION SPECIFICALLY IDENTIFIED ON THIS DRAWING. © 2004 REDD TEAM MANUFACTURING, INC.

REDD Team Manufacturing, Inc.  
 A Division of Alcoa Extrusions, Inc.  
 6599 S.R. 21  
 KeySTONE Heights, Florida 32856  
 Phone: 1-800-948-3868 Fax: 1-352-943-0218



FOR QUOTE PURPOSES ONLY

UNIVERSAL RAMP SYSTEM  
 ALUMINUM ACCESS RAMP SYSTEM  
 WITH 38VP VERTICAL POCKET CURVED HANDRAILS

DATE: 2004  
 SALES URS  
 SALES URS  
 FILE # PLM  
 SHEET NUMBER  
 38VP-90-2